



2427 Union St.

Floor 2

Blue Island, IL 60406

August 27, 2018

Project #: A01A2HT

In accordance with the terms of the ordinance granting certain rights to AT&T, permission is hereby requested to perform work as indicated on the attached plan.

WORK DESCRIPTION:

AT&T contractor to hand dig & place 1-4" duct – 5' from pole #237 to new 864 PFP. Place precast pad for 864 PFP cabinet. Place new ground bed. Please refer to the prints.

Approximate date work will start: Upon permit/plan approval.

Approximate date work will stop: Within 90 days or permit approval.

Work will be performed by: [] AT&T [X] Contractor

Type of Restoral: Restore to same or better condition.

Yours Truly,

Vikki Thomas

AT&T Engineer

708.396.7648

Permission is hereby granted:

GENERAL CONSTRUCTION NOTES:

1. LOCATE ALL UNDERGROUND OBSTRUCTIONS PRIOR TO DIGGING CONTACT J.U.L.I.E. AT 8-1-1 TWO BUSINESS DAYS IN ADVANCE TO DIGGING
2. RESTORE ALL DISTURBED GROUNDS TO ORIGINAL OR BETTER CONDITION AS SOON AS POSSIBLE OR WITHIN TWO (2) WEEKS AFTER CONSTRUCTION IS COMPLETE.
3. AT&T CONTRACTOR TO PLACE CONDUIT NO LESS THAN 24" DEEP.
4. AT&T CONTRACTOR TO PROVIDE ALL BARRICADES AND WORK AREA PROTECTION.
5. AT&T CONTRACTOR IS REQUIRED TO KEEP ALL ROADWAY PAVEMENT, CURBS, GUTTERS AND STORM WATER COLLECTORS FREE OF MUD AND OTHER DEBRIS AT ALL TIMES DURING CONSTRUCTION.
6. ALL PROPOSED WORK IS IN EXISTING PUBLIC RIGHT OF WAY AND/OR UTILITY EASEMENT.
7. TUNNEL ALL TREES PER BUREAU OF FORESTRY GUIDELINES.

- CAUTION: VOLTAGE RANGES FROM 301 TO 15KV

- THIS PROJECT REQUIRES COORDINATION WITH UT: A01B65Q

- ① HAND DIG & PL. 1-4" DUCT - 5' POLE # 237 TO NEW 864 PFP
- ② PL. PFP 52"X50"X4" PRECAST PAD FOR 864 PFP CABINET
- ③ PL. NEW GROUND BED

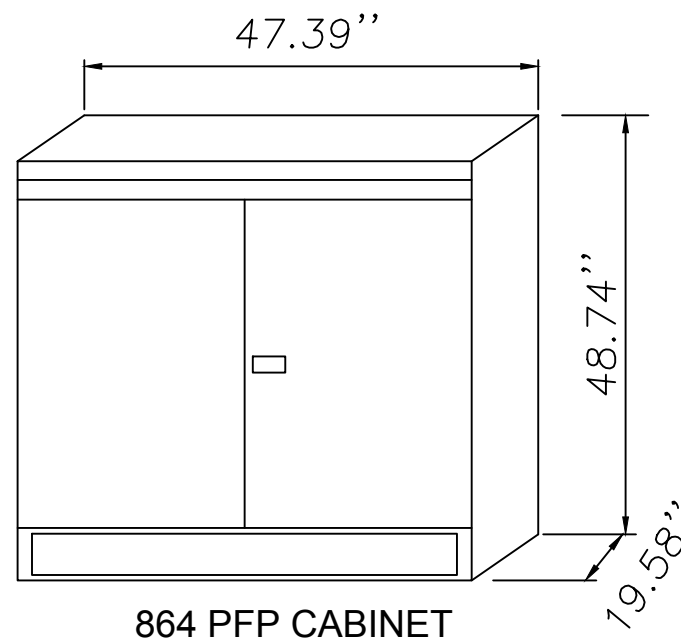

EXCAVATION DATA
HAND DIG LENGTH
5 SQ FT.

PERMIT PRINT



ISSUE	DATE
1	08/27/18

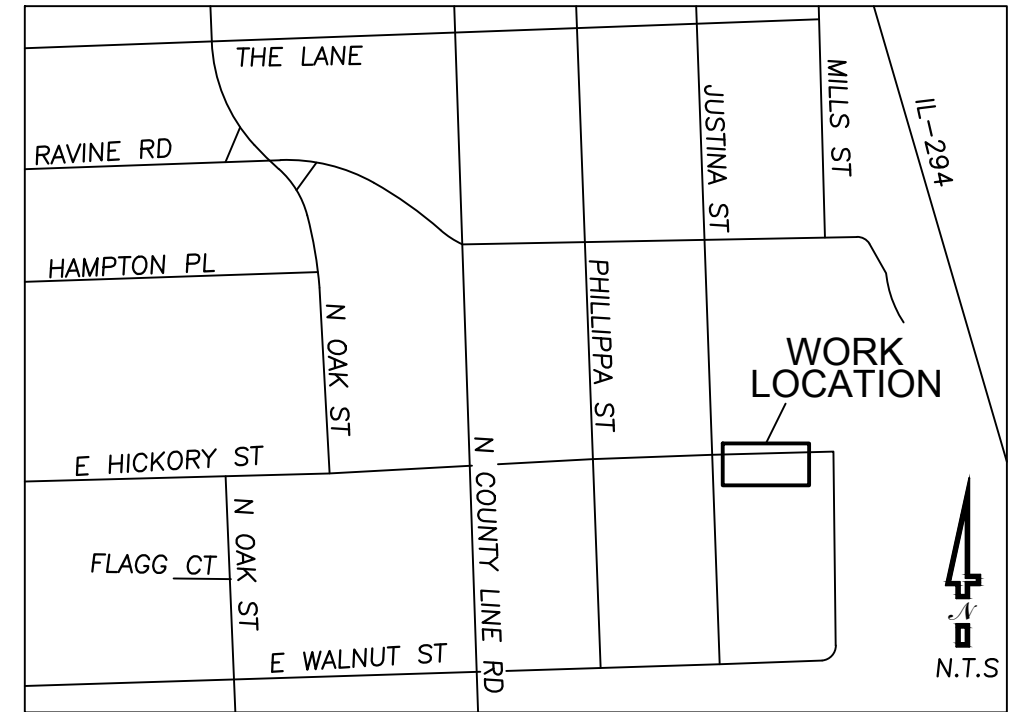

VICINITY MAP

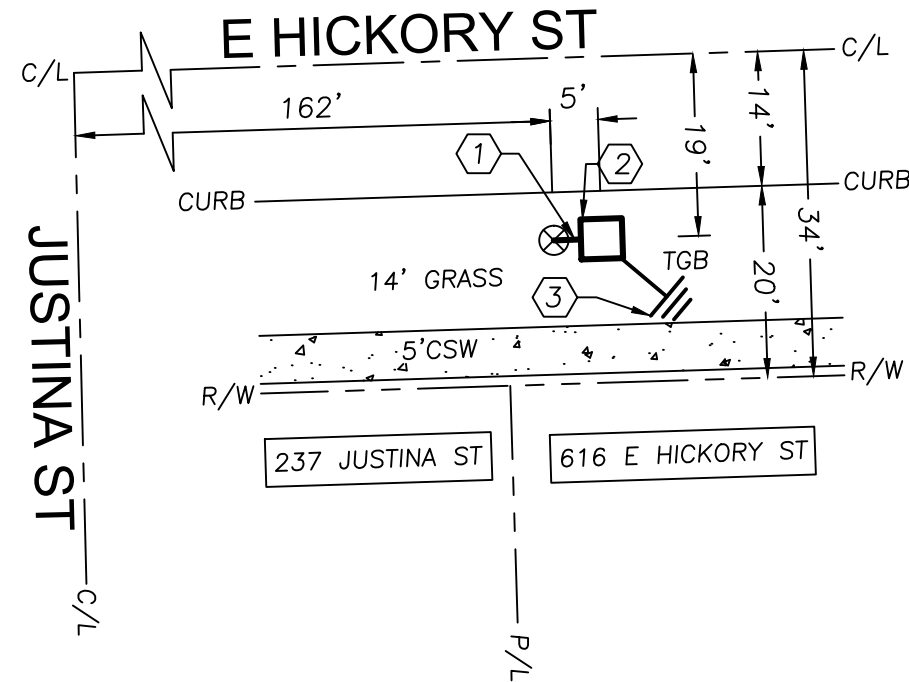

Call Before You Dig

0' 1/2" 1"
0' 10' 20'
SCALE

AT&T PROJECT: A01A2HT
 ENGINEER: CHRISTINE SUNDBERG
 TEL # (708) 396-3282
 QUARTER SECTION: NE-06
 MUNICIPALITY: HINSDALE
 TOWNSHIP: LYONS
 WIRE CENTER: HINSDALE
 COUNTY OF: COOK

PREPARED BY: J. KAUSHAL

Consulting, LLC
 1845 W. Orangewood Ave., Suite 300
 Orange, CA 92868
 (949) 250-0004 / FAX (949) 250-0006

DWG 1 OF 1 REV. NO. _____